

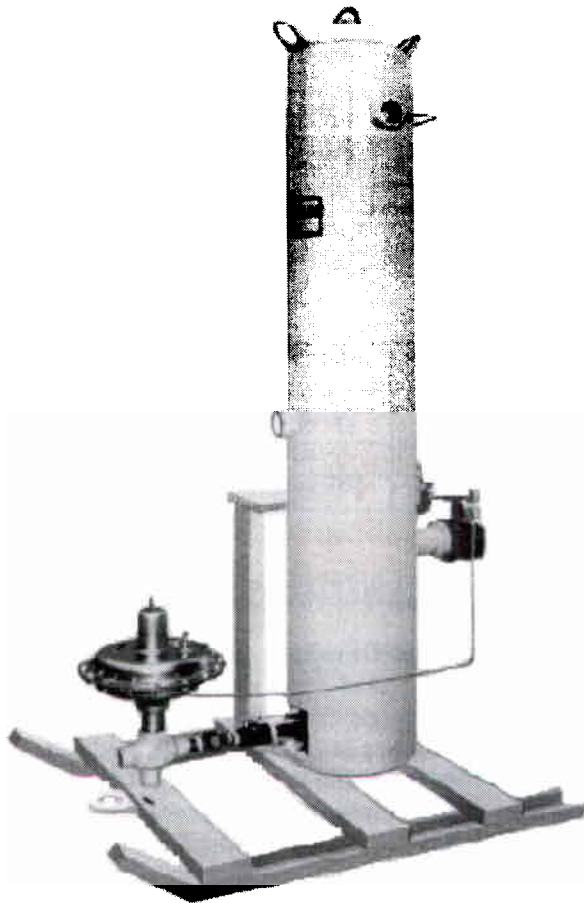

Making the World's Air Dryer

Form No. GWD-1

PSB NATURAL GAS SEPARATOR - DEHYDRATOR



FEATURES

- Eliminates freeze-ups at pressure reducing valves.
- Protects meters, regulators and instruments downstream.
- PSB superior design and construction.
- Extremely efficient reduction of moisture.
- Low desiccant consumption.
- Simplified installation.
- Reduced maintenance.
- Automatic draining.
- Skid-mounted for easy field handling and installation.
- Custom designed units for special applications.

The General Air Division of PSB Industries Inc. manufactures the most extensive line of compressed air and gas dryer on the market today.

The PSB Natural Gas Separator-Dehydrator was developed following extensive and comprehensive tests, involving desiccant type evaluation, flow velocities and moisture separation. It is designed to provide liquid phase and excess moisture separation from natural gas supplies at the well head, meter sites or point of use. Properly applied, the Separator Dehydrator is adequate to meet most contract dehydration specifications.

It eliminates freeze-ups at pressure reducing valves and protects meters, regulators and instruments downstream for the unit.

The PSB unit combines efficient liquid water separation, moisture vapor removal and draining into one single welded pressure vessel designed and built in accordance with the current ASME code.

OPERATION

Wet, dirty gas enters the lower section of the vessel. Liquid, water and solid contaminants are removed in the generously sized mechanical separator equipped with internal pitched baffles. This design also assures elimination of other liquids such as brine, alcohols, glycols, and casing head gasoline that occur periodically.

The gas then flows upwards through a bed of desiccant tablets which attracts and removes moisture vapors. The desiccant is slowly consumed as it adsorbs moisture from the gas stream and resulting liquid collects in the lower section of the vessel. Automatic draining is accomplished through a liquid level controller with a diaphragm actuated drain valve.

The gas, now clean and dry, exits through a stainless steel screened outlet. Conservatively sized flow velocities insure adequate dwell time and no carry over of desiccant.

PSB DESICCANT

Developed specifically for natural gas drying.

Tablet desiccant is hygroscopic and is slowly consumed as it comes in contact with the moisture laden gas. The exclusive performance proven desiccant formula allows for better absorption with lowest desiccant consumption. Consumption rate and operating cost is directly related to operating pressure and moisture content (temperature) of the gas. Best performance is achieved with high pressures and low temperatures.

Pressure drop through the bed is insignificant.

ENGINEERING DATA

CAPACITIES:

Top numbers are MCFD (Thousands of cubic feet per day)

Bottom numbers are CFM (Cubic feet per minute)

Model	100 psig	250 psig	500 psig	750 psig	1000 psig	1250 psig	1450 psig
GWD 625	88 61	203 141	395 275				
GWD 900	88 61	203 141	395 275	587 408			
GWD 1450	88 61	203 141	395 275	587 408	780 542	1026 712	1196 830

PERFORMANCE RESIDUAL #H₂O/MMSCF

INLET TEMP	40°F	50°F	60°F	70°F	80°F
1450 PSIG	.8	1.4	1.8	2.5	3.5
1250 PSIG	1.0	1.5	2.0	2.7	3.8
1000 PSIG	1.2	1.6	2.2	3.0	4.1
750 PSIG	1.5	1.9	2.7	3.5	5.0
500 PSIG	1.9	2.7	3.6	5.0	7.0
250 PSIG	3.5	4.5	6.4	9.0	14.0
100 PSIG	7.0	10.0	16.0	22.0	30.0

DESICCANT CONSUMPTION (LBS./MMSCF)

INLET TEMP	40°F	50°F	60°F	70°F	80°F
1450 PSIG	.92	1.4	2.2	3.4	4.8
1250 PSIG	1.2	1.8	2.6	3.8	5.6
1000 PSIG	1.4	2.0	3.0	4.6	7.0
750 PSIG	1.7	2.4	3.6	5.4	8.4
500 PSIG	2.0	3.2	4.8	7.6	11.6
250 PSIG	3.0	4.4	8.4	13.4	24.0
100 PSIG	4.0	12.2	22.0	33.0	51.0

MMSCF = Millions of Standard Cubic Feet

DIMENSIONS (inches)

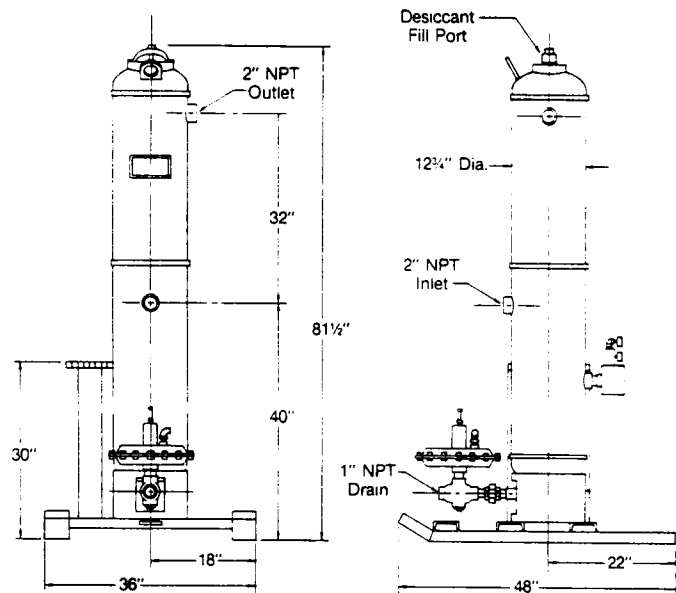

MODEL	MWP	Inlet/Outlet Con.	Drain Con.	Unit Wt.	Des. Wt.
GWD 625	625	2" NPT	1" NPT	375	120#
GWD 900	900	2" NPT	1" NPT	425	120#
GWD 1450	1450	2" NPT	1" NPT	750	120#

INSTALLATION AND MAINTENANCE

The PSB Separator-Dehydrator is shipped ready for easy field installation. Skid base eliminates need for special concrete pad or foundation. Locate unit at the highest continuous pressure point in the system to achieve best possible performance. Install with a valved bypass for ease of periodic desiccant inspection and replenishment. All sizes have a 1" coupling in the top for mounting of a relief valve supplied by the customer. Following installation, fill vessel with desiccant to the recommended level, close filler port and pressurize slowly.

Draining is automatic through a liquid level controller with diaphragm actuated drain valve.

The only maintenance required is periodic checking of the desiccant level and periodic adding of desiccant. Normally, replenishment is required only every 2-3 weeks. It is suggest that a usage patter be logged for the separator-dehydrator.