



HYDRYER® TYPE P
Heat Regenerative
Dryers



GENERAL AIR
Making the world's air dryer

ISO 9001 CERTIFIED

General Air Type P Hydryer® Heat Regenerative Systems

Introduction

General Air **Type P Hydryers** are electric heat regenerative dryers, designed primarily for general plant and instrument air service. They economically provide clean, dry compressed air or gas, with pressure dew points of -40°F or lower.

Type P dryers are dual-tower units operating on a standard 8-hour NEMA cycle (4 hours drying and 4 hours regenerating). Optional cycle times are available for custom applications. One tower dries the wet compressed air or gas; the drying function then switches automatically to the other tower while the first tower is regenerated.

Principles of Operation

• Adsorption (Drying)

The wet fluid stream (air or gas) enters the on-stream tower through the 4-way valve and passes downward through the desiccant bed, where the water vapor is adsorbed. The clean, dry air or gas then exits the dryer.

• Regeneration Heating

Regeneration begins with the slow depressurization of the off-stream tower. A small portion of dried air or gas (expanded to near-atmospheric pressure to increase its ability to carry water vapor) is heated and passed across the adsorbent bed, countercurrent to the adsorption flow. The liberated moisture is carried out of the bed.

• Regeneration Cooling

When regeneration heating is complete, the cooling cycle begins. The desiccant bed is cooled by purging a small volume of dried air or gas across the bed, with the heater turned off.

Demand Drying Energy Management System (Optional)

Dryers are sized for maximum design flow rate and maximum design moisture load (based on minimum pressure and maximum temperature). In other words, dryers are sized for “worst case” operating conditions. The dryers, however, are rarely operated under this set of conditions. Operating the dryers on a fixed cycle wastes energy since the actual moisture load is less than design and the need for regeneration is reduced.

The **Demand Drying Energy Management System** is designed to enhance the overall operating efficiency of Type P dryers by consuming only as much energy as is necessary to maintain the required outlet dew point throughout the entire operating range of the dryers.

An air or gas sample is continuously monitored from the on-stream (drying) desiccant bed. If the humistat's* set point has been reached by the end of the 4-hour drying cycle, tower switchover will occur. If not, the demand cycle controller will put the solid-state timer on hold. The timer stays on hold until the humistat reaches its set point. Then, the timer resumes operation, and tower switchover occurs. The timer now resumes another 4-hour drying cycle.

The optional General Air **Demand Drying** control system will control the cycle time to get full adsorption capacity from the desiccant bed during every cycle. Equipment wear-and-tear is also minimized with **Demand Drying** since moving parts (4-way switching valve, actuator, regeneration valves) cycle less frequently.

**An optional digital hygrometer can be used for moisture monitoring.*

Features and Benefits

Standard

- **Removable Electric Heater** – The flanged electric heater is not in direct contact with the desiccant. This protects the desiccant from extreme temperatures which result in premature desiccant failure due to attrition.
- **Heater Protection** – Heater element skin temperature is limited to 1,100°F by a thermocouple and solid-state board. This safety feature virtually eliminates heater burnout.
- **Automatic Heating/Cooling Termination** – The heating/cooling termination thermocouple automatically terminates regeneration heating and cooling, prior to the fixed cycle time, during periods of low moisture loading. This feature saves energy and reduces equipment wear.
- **Automatic Depressurization and Re-pressurization** – These occur slowly, at the start and completion of regeneration respectively, to prevent excessive desiccant abrasion and/or fluidization.
- **Fully Automatic Operation** – The General Air Model 48 solid-state control board provides a reset button and status LEDs for Board Failure, Tower On Stream Status and Heater Failure.

Other Standard Features:

- ASME Code-stamped 150 PSIG MWP carbon steel vessels.
- Standard -40°F pressure dew point.
- Stainless-steel inlet diffusers and desiccant support screens.
- Desiccant fill and removal ports.
- Initial fill of activated alumina desiccant.
- Non-lubricated 4-way switching valve.
- NEMA 4 electrical enclosure.
- Pressure and temperature gauge (per tower).
- Relief valve.
- Purge flow muffler.
- Preset purge flow orifice.
- Control transformer (120/1/60).
- Standard User Panel featuring on/off switch, malfunction alarm and power-on lights.
- High temperature-resistant paint.
- Incoloy-clad heating elements.
- 460/3/60 electrics.
- Auxiliary purge cooldown circuit on 243P - 363P.

Optional

- **Demand Drying** – See page 2.
- **Cycle Failure Alarm With Light (via pressure switches)** – If cycle failure occurs, the Model 48 Controller will stop timing. The Hydryer will not advance in the sequence of operation until the cause of the alarm has been corrected.
- **High Humidity Alarm and Light** – A lithium chloride sensor is used to measure the moisture content of the outlet gas from the Hydryer. An alarm indicates when the gas moisture content is greater than the sensor set point.

Other Optional Features:

- **Purge flow meter with throttle valve.**
- **Color-change moisture indicator (installed).**
- **Dryer status lights: tower on stream, heater on, tower regeneration.**
- **Switching failure alarm with light (via limit switch).**
- **NEMA 7 and NEMA 4-purged enclosures.**
- **Moisture analyzer and alarm. Digital readout of outlet pressure dew points down to -110°F.**
- **Semi-automatic operation.**
- **Higher working pressure available.**
- **12-hour, 16-hour and longer NEMA cycles available.**
- **Heat guards on towers for personnel protection.**
- **Programmable controllers available.**
- **Special package for drying cylinder gases.**
- **Desiccants other than activated alumina (molecular sieve, etc.) are available for special applications.**
- **Oversize piping, if required.**
- **Other voltages available.**
- **Auxiliary purge cooldown on 83P - 203P.**
- **For custom applications, materials, or design criteria, contact General Air.**
- **Atmospheric blower purge.**
- **Closed-loop regeneration.**

Flow Diagram – Standard

(Under 150 PSIG MWP)

- | | |
|---|---|
| <ol style="list-style-type: none"> 1. Electric Heater 2. Desiccant Bed Support 3. Desiccant 4. 4-Way Transfer Valve 5. Outlet Check Valve 6. Purge Orifice 7. Purge Outlet Valve (Depressurization Valve) 8. Purge Muffler 9. Thermocouple - Control | <ol style="list-style-type: none"> 10. Thermocouple - Limit 11. Thermocouple - Auto Heat/Cool Termination 12. Desiccant Removal Port 13. Desiccant Fill Port 14. Wet Air Inlet 15. Dry Air Outlet 16. (Optional) Demand Drying Humistat and Filter 17. (Optional) Demand Drying Sample Port and Valving 18. Auxiliary Cooling Purge Line (243P thru 363P standard) |
|---|---|

NOTE:
Relief Valve and some options not shown.

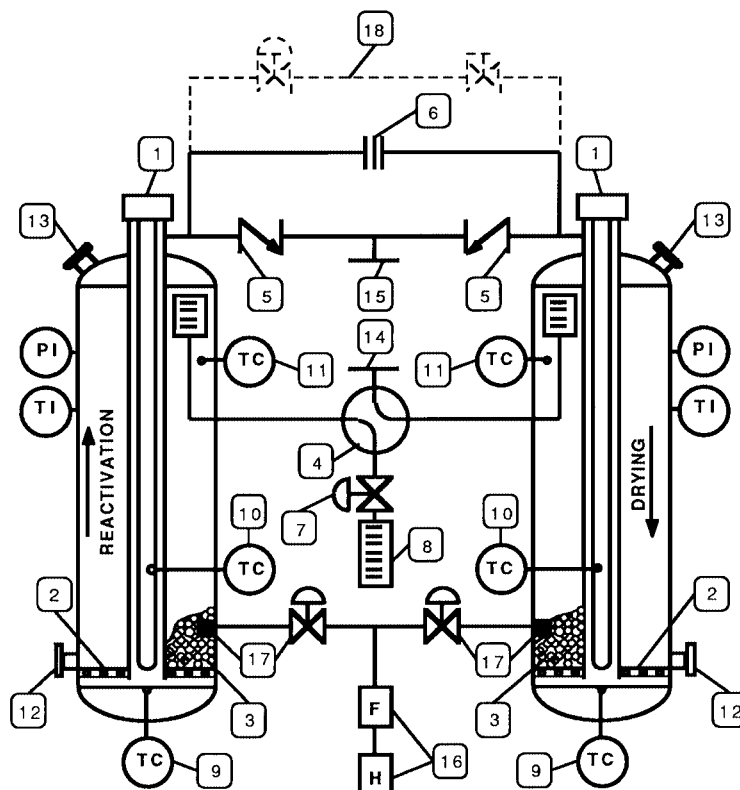

Prefilters and Afterfilters for Maximum Protection

Every regenerative compressed air dryer must be equipped with a coalescing prefilter to protect the desiccant beds from oil and/or free water contamination from the compressed air supply. This ensures top efficiency and the longest possible desiccant life. A particulate afterfilter is a must for collecting desiccant dust inherent to regenerative type dryers.

The General Air coalescing prefilters and particulate afterfilters listed on page 5 are available as installed assemblies, complete with all piping and valves, or as singular components for customer installation on any regenerative dryer not so equipped. A recommended flow diagram is also shown on page 5.

TYPICAL AIR FLOW THRU DRYER AND FILTERS

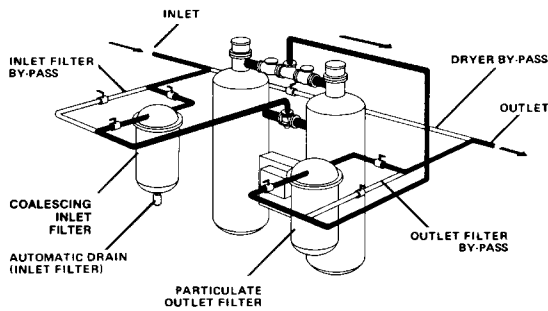

The filters depicted are in-line as installed on Models 203P and smaller.

PREFILTER and AFTERFILTER ASSEMBLIES

Installed complete with all piping and bypass valves:

| Dryer Model | Coalescing Prefilter | Automatic Float Drain | Particulate Afterfilter |
|-------------|----------------------|-----------------------|-------------------------|
| 83P | C15 | 71034-39 | P15 |
| 103P | C30 | 71034-39 | P30 |
| 123P | C50 | 71034-39 | P30 |
| 143P | CX100 | 71034-39 | P50 |
| 163P | CX160 | 71034-39 | PX100 |
| 183P + 203P | CX200 | 71034-38 | PX160 |
| 243P | CX300 | 71034-38 | PX200 |
| 253P | CX400 | 71034-38 | PX200 |
| 303P | CX600 | 71034-38 | PX400 |
| 363P | CX800 | 71034-38 | PX400 |

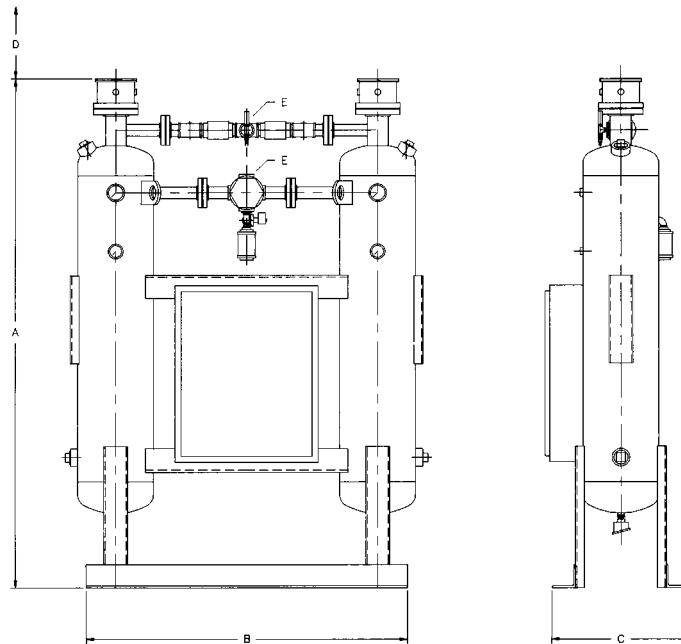

Type P Hydryer – General Specifications

| Model | 83P | 103P | 123P | 143P | 163P | 183P | 203P | 243P | 253P | 303P | 363P |
|--|-------|-----------|-----------|-----------|-------|-------|-------|-------|-------|-------|-------|
| “A” Height (In.) | 78 | 87 | 89 | 104 | 115 | 116 | 114 | 119 | 129 | 128 | 134 |
| “B” Width (In.) | 51 | 56 | 62 | 64 | 68 | 72 | 77 | 88 | 88 | 98 | 107 |
| “C” Depth (In.) | 19 | 21 | 24 | 25 | 23 | 25 | 26 | 29 | 29 | 39 | 44 |
| “D” Overhead Clearance Recommended (In.) | 57 | 55 | 55 | 75 | 77 | 77 | 87 | 75 | 95 | 95 | 95 |
| “E” Inlet & Outlet Pipe Size (In.) | 1 NPT | 1-1/2 NPT | 1-1/2 NPT | 1-1/2 NPT | 2 FLG | 2 FLG | 2 FLG | 3 FLG | 3 FLG | 3 FLG | 4 FLG |
| Total Est. Shipping Weight (Lbs.) | 810 | 1,160 | 1,440 | 1,745 | 2,320 | 2,640 | 2,960 | 3,520 | 4,360 | 6,400 | 8,800 |
| *Capacity SCFM @ 100 PSIG and 100°F | 100 | 200 | 300 | 425 | 600 | 800 | 1,000 | 1,200 | 1,550 | 2,200 | 3,200 |
| Heater KW | 1.3 | 2.5 | 3.7 | 5.4 | 8.0 | 9.8 | 12.0 | 14.3 | 19.2 | 28.8 | 39.3 |

MWP – 150 PSIG. For non-standard conditions, contact General Air.

* Capacity is SCFM based on 14.7 PSIA @ 68°F at compressor suction when the dryer inlet is at 100°F maximum and 100 PSIG minimum. Verify system operating conditions prior to selecting a dryer.

Atmospheric Blower – Purge Option

Dryer Operation:

- **Adsorption (Drying)**

Compressed air enters the dryer and flows downward through the desiccant bed where the water vapor is adsorbed onto the desiccant. The dry air exits the dryer.

- **Regeneration Heating (Figure 1)**

While one tower is on stream, drying, the other tower is off stream, regenerating. Regeneration is accomplished using ambient air for the heating portion, which reduces purge loss and saves energy. The off-stream tower is slowly depressurized. Ambient Blower Purge air is then passed downward through the internal heater can, where it is heated to 550°F. The hot air then flows upward through the desiccant bed, counter-current to the adsorption flow. The desorbed water vapor exits through the purge valve and muffler to the atmosphere.

- **Regeneration Cooling (Figure 2)**

Once regeneration heating is complete, the blower stops, and approximately 5% of the dry outlet air is diverted through an orifice to the regenerating tower for reactivation cooling. The very dry cooling air is expanded to atmospheric pressure and passes across the desiccant where it desorbs the remaining moisture while cooling the desiccant.

The purge air used for this portion of regeneration averages 1-2% of the total inlet capacity.

Figure 1
Heating

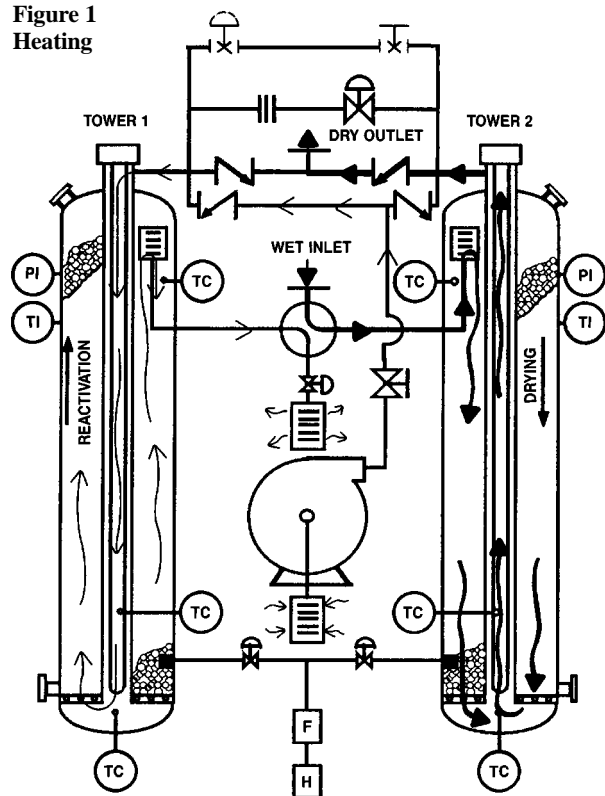
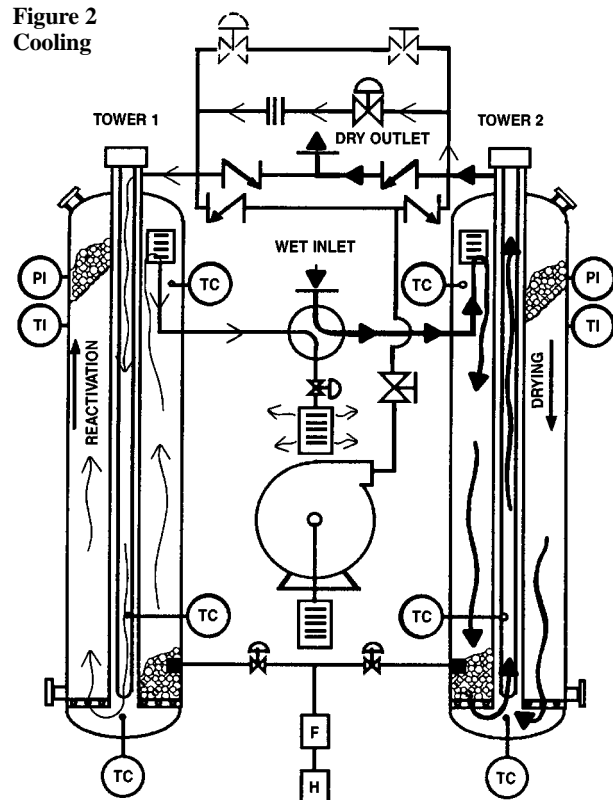
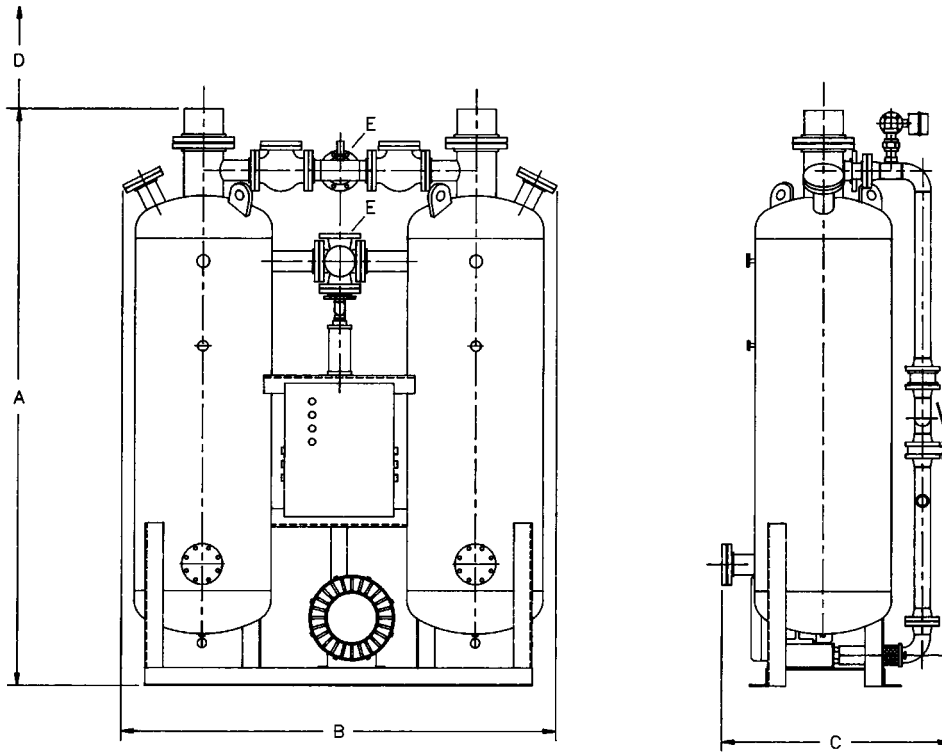

Figure 2
Cooling



Feature/Benefit Analysis of Blower Option:

- **Less Purge Required** – Less purge means lower energy costs. The blower option will pay for itself in less than one year under normal operating conditions.
- **Oil-Free, Pulsation-Free Blower Air (via a Vortex Blower)** – Minimizes desiccant abrasion or contamination.
- **Low Noise** – Less than 85 dbA operation.
- **Blower Intake Filter** – Protects blower and desiccant from contaminants.
- **Dry Purge Cooling Step** – Assures that the desiccant is cool for proper adsorption. Eliminates any possibility of preloading the desiccant with moisture.



Type PC Hydryer – General Specifications

| Model | 83PC | 103PC | 123PC | 143PC | 163PC | 183PC | 203PC | 243PC | 253PC | 303PC | 363PC |
|---|-------|-----------|-----------|-----------|-------|-------|-------|-------|-------|-------|-------|
| “A” Height (In.) | 84 | 87 | 89 | 104 | 115 | 116 | 114 | 119 | 128 | 128 | 134 |
| “B” Width (In.) | 51 | 56 | 62 | 64 | 68 | 72 | 77 | 88 | 88 | 98 | 107 |
| “C” Depth (In.) | 22 | 24 | 24 | 27 | 28 | 29 | 29 | 36 | 38 | 52 | 59 |
| “D” Overhead Clearance Recommended (In.) | 57 | 62 | 62 | 78 | 85 | 85 | 85 | 76 | 95 | 95 | 95 |
| “E” Inlet & Outlet Pipe Size (In.) | 1 NPT | 1-1/2 NPT | 1-1/2 NPT | 1-1/2 NPT | 2 FLG | 2 FLG | 2 FLG | 3 FLG | 3 FLG | 3 FLG | 4 FLG |
| Total Est. Shipping Weight (Lbs.) | 850 | 1,200 | 1,500 | 1,850 | 2,450 | 2,800 | 3,150 | 3,800 | 4,600 | 6,800 | 9,300 |
| *Capacity - Inlet SCFM @ 100 PSIG and 100°F | 100 | 200 | 300 | 425 | 600 | 800 | 1,000 | 1,200 | 1,550 | 2,200 | 3,200 |
| Heater KW | 1.3 | 2.5 | 3.7 | 5.4 | 8.0 | 9.8 | 12.0 | 14.3 | 19.2 | 28.8 | 39.3 |
| Blower KW | 0.25 | 0.38 | 0.60 | 0.90 | 1.0 | 2.0 | 2.2 | 3.0 | 4.0 | 7.8 | 10.0 |

MWP – 150 PSIG. For non-standard conditions, contact General Air.

* Capacity is SCFM based on 14.7 PSIA @ 68°F at compressor suction when the dryer inlet is at 100°F maximum and 100 PSIG minimum. Verify system operating conditions prior to selecting a dryer.



Manufacturers of quality products since 1945



GENERAL AIR
Making the world's air dryer

PSB INDUSTRIES INC.
*General Air Division
1202 West 12th Street
Erie, PA 16501 USA
Phone: 814-453-3651
Toll Free: 800-829-1119
Fax: 814-454-3492
E-mail: psb@genair.net
www.psbindustries.com*

Printed in U.S.A.
Form No. GHP, PDF-7/02

Your Contact Is: