

# INSTALLATION INSTRUCTIONS FOR "PZLD" PNEUMATIC ZERO LOSS DRAIN



The PZLD is designed for trouble-free and maintenance-free draining of unwanted accumulations of condensation and other foreign matter from any collection point in a compressed air system without the need for electricity.

## INSTALLATION

### CAUTION: COMPRESSED AIR CAN BE DANGEROUS.

Before attempting to install the drain, be certain that the pressure vessel on which the drain will be installed is completely depressurized.

The drain should not be installed in areas that are exposed to freezing temperatures (heater option is available). Be certain the air system pressure does not exceed the 250 PSI working pressure of the drain and the pressure to the control system does not exceed 130 psi. The inlet temperature should not exceed 180 degrees F.

Connecting the drain to the air system should be done by using one of the recommended installation diagrams shown herein. The installation of a strainer is not required or recommended.

Install the drain as close to the source to be drained as possible. Since the PZLD uses gravity to fill the reservoir, the entire drain must be installed below the vessel to be drained when using the top inlet. If flexible tubing is used on the discharge, be certain it is properly fastened to prevent it from whipping when the drain discharges the condensation.

The PZLD will accept condensation from either the top or the bottom of the reservoir. We recommend the use of the top entry port. If the bottom inlet is used, then a vent line must be used. The vent line should be installed down stream from the vessel that is being drained. This will insure that the air in the reservoir will properly exit as the condensation fills the tank and replaces the air. Install the vent line in the 1/8" port located on the side of drain. The other end of the vent line should be run back to the air system to a point just down stream from the source that is being drained. Use nongalling pipe sealant on all joints. The use of shut-off valves, unions and bypass valves is recommended. A backup wrench should be used on the discharge ball valve to prevent it from turning and causing the linkage to bind.

The inlet port that is not used must be plugged by using a standard 3/4" npt plug. When using the top inlet, any reduction in the 3/4" pipe size is not recommended and the PZLD reservoir cannot be higher than the bottom of the vessel that is being drained. It is best to run the drain in a downward pitch from the bottom of the vessel being drained to the PZLD inlet.

The power to operate the PZLD comes from compressed air. **ONLY CLEAN DRY AIR SHOULD BE USED.** The supply pressure should be between 80 and 130 psig. The PZLD is supplied with an inlet filter, which should be installed in the PZLD head (See Dwg 2 on back). The use of unfiltered air can

cause the drain to fail. Once the drain is installed, close the By-Pass drain valve and open the Shut-Off valve. The pressure vessel can now be repressurized.

## CHECKING THE DRAIN'S OPERATION

After installation is complete and the drain is on line, a check should be made that the condensation is properly entering the reservoir. This can easily be done by looking through the translucent reservoir.

If condensation is not entering the reservoir, check for the following:

1. Make sure the auxiliary shut-off valve is open.
2. Do not use the bottom inlet on the PZLD without installing a vent line.
3. If a vent line is installed, make sure it is down stream from the vessel that is being drained.
4. Be certain that the PZLD reservoir is not higher than the vessel that is being drained. This is very important when using the top inlet on the PZLD reservoir.
5. Check to make sure the vessel being drained has condensation in it.

If the top inlet is being used and no condensation is entering the PZLD reservoir, and all the above items have been checked, we recommend that the bottom inlet be used with a vent line out of the top.

If condensate fills the reservoir and the drain does not operate, check to see if control line air is supplied to the control line port. The supply of control line air can be checked by pushing the test button. If the unit does not operate, then no air is being supplied or the inlet filter is plugged.

## OPTIONS

- **Stainless Steel Ball Valve**
- **Heater**
- **High Level Alarm**

## WARRANTY

The PZLD is warranted to be free from defects in workmanship and materials for a period of one year from the date of shipment. The liability of the manufacturer is limited to repair or replacement of the drain at its option. In no event shall the manufacturer be liable for special or consequential damages or for delay in performances of this warranty.

**CAUTION:** Any attempt to repair the drain without authorization will void any warranty.

## IN GENERAL

In order for the condensate to properly enter the PZLD reservoir, the condensate line to the PZLD must always be installed below the bottom of the vessel to be drained. It is equally important to provide a means for the air that is contained in the reservoir to escape (vent) as the condensate enters the reservoir. If the air cannot escape, the condensate will not enter the reservoir. Below are suggestions on how to best install the PZLD on typical types of vessels that have to be drained of condensate. However, it is possible to install the PZLD without a balance line (Dwg. not shown), providing the condensate enters the top inlet and the flow rates are less than 9 GPH (750 cfm for an aftercooler or 1500 cfm drier) for a 1/2" drain line and 19 GPH (1500 cfm for an aftercooler or 3000 cfm drier) for a 3/4" line. The use of unions and shut-off valves are recommended for both the condensate line and the balance line.

## RECEIVER TANK

The preferred installation for a PZLD on a receiver tank is having the condensate enter the top inlet port and having the balance line go back to the tank at a position that is above the level of the condensate (Dwg. 1).

## FILTER and AFTERCOOLER MOISTURE SEPARATOR

If a cyclone separator or filter has pipe plugs located in the top of the head, the plug closest to the discharge pipe should be removed and the balance line should be installed (Dwg. 2). If there is no provision on the cyclone separator or filter for a balance line, install it in the discharge side of the pipe line and as close to the cyclone separator as possible.

## REFRIGERATED DRYER

If a balance line is required, it must be connected to the port located on top of the separator that is closest to the discharge side (Dwg. 2), or between the separator and the air-to-air heat exchanger. If a port is not available as described above, then venting to atmosphere is recommended. When venting to atmosphere, the condensate should enter through the bottom entry port on the drain. The bleed or needle valve is installed on the 1/8" NPT vent port and allows the air in the PZLD reservoir to escape to the atmosphere (Dwg 3). The bleed valve (not included) should be adjusted so that only 3 to 5 bubbles per second are visible. We do not recommend installing a vent line down stream from the dryer. The vent line can be a conduit for transferring moisture from the drain to the previously dried air. This can result in unwanted moisture being sent down stream.

## INTERCOOLERS

Install the condensate drain line into the upper port only. This will prevent the possibility of condensate being drawn back into the intercooler on some systems. It is important that the vent line be installed on the same stage that is being drained or to atmosphere.

## BALANCE LINE

As mentioned above, both the use and the placement of a balance line is very important. Most drain failures are the result of an improper balance line installation. The balance line should be 1/4" tubing or larger, and installed on top of a pipe or vessel, not the bottom. A needle valve is recommended for controlling the air flow. Avoid having any loops or low areas in the balance line that might allow moisture to collect in the line and prevent the passage of air from the drains reservoir.

Dwg. 1

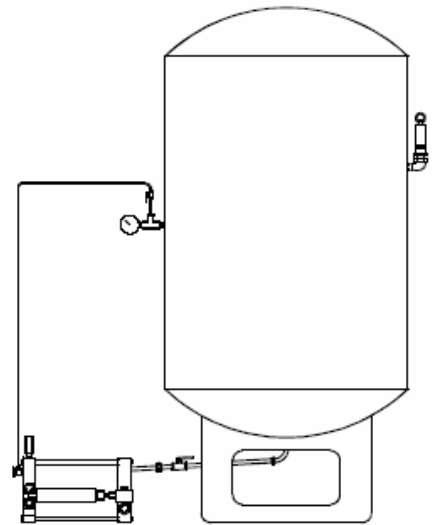

Dwg. 2

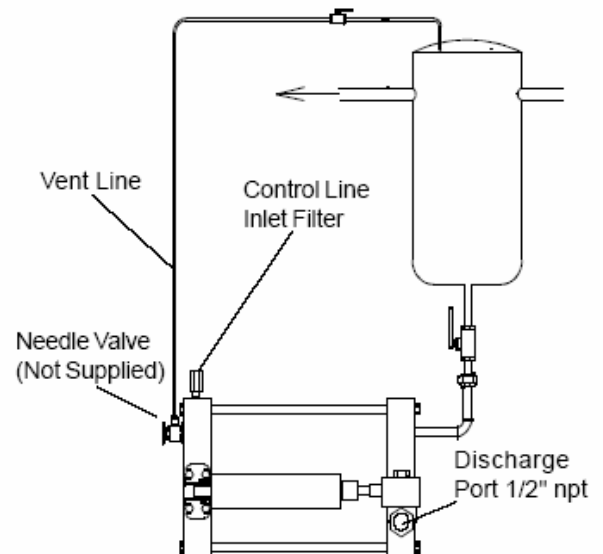

Dwg. 3

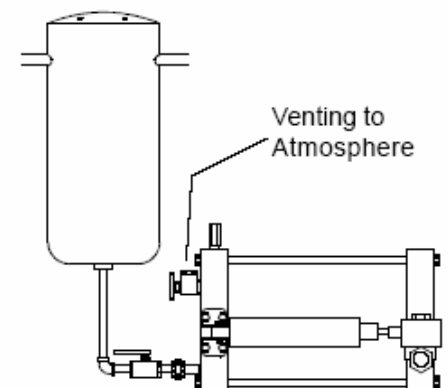

## PZLD Drain Cleaning Procedure

1. Isolate drain and depressurize

!!!! Caution!!!!

!!! Do not attempt cleaning or maintenance when unit is pressurized!!!

2. Remove Drain from air system. This step will differ from application to application depending on how the unit was affixed into the air system.
3. Loosen and remove (Qty. 4)  $\frac{3}{4}$ " nuts (#1) from the 12" bolts (#2) that run through the 2 endplates. (#3 & 3a)
4. Remove (Qty. 4) 12" bolts.
5. The end plate (#3) that includes the Discharge Ball Valve will pivot away from the drain vessel. This will allow you to remove the vessel tube (#4) for cleaning and/or internal maintenance.
6. Remove and dispose of the (Qty. 2) 5" endplate o-rings (not shown) located in machined grooves for vessel.
7. Clean vessel, endplates and trigger block with mild soap or de-greaser solution. Avoid harsh cleaners or solvents as it may degrade the strength of the vessel material. Be careful not to scratch the vessel
8. Install new endplate o-rings into each of the grooves of the end plates.
9. Sandwich the vessel tube (#4) between the endplates, making sure the vessel tube is seated in the machined grooves of the endplate.
10. Re-insert (Qty. 4) 12" bolts (#2) through endplates starting from the endplate with control tubing.
11. Thread (Qty. 4)  $\frac{3}{4}$ " nuts (#1) on to 12" bolts and snug equally. Check to ensure that the vessel is fully engaged into the end pieces
12. Tighten nuts equally using a  $\frac{3}{4}$ " socket, wrench, or crescent. Use a crossing pattern.

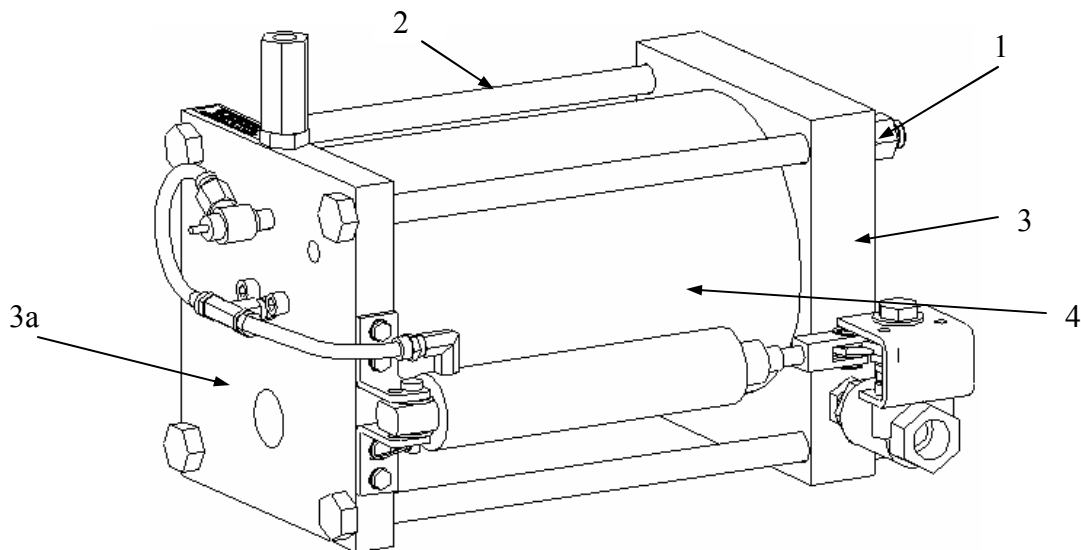

**PSB Industries Inc.**  
**General Air Division**  
1202 West 12<sup>th</sup> Street • Erie, PA 16501 USA  
Phone: 814-453-3651 • Fax: 814-454-3492  
[www.PSBINDUSTRIES.com](http://www.PSBINDUSTRIES.com)

# INSTALLATION INSTRUCTIONS FOR “PZLD” HEATER OPTION



The PZLD is available with several options, one of which is an immersion type heater that is designed to keep the reservoir on the PZLD from freezing to temperatures of minus 20 degrees F. The heater is mounted to a Nema 4 type enclosure for outdoor use. The heater has a built in thermostat that will turn the heater on at approximately 40 °F. and off at approximately 65 °F. The standard voltage is 120V/1PH/60HZ with a 100 watt usage. The heater is shipped loose for field installation on the PZLD.

## INSTALLATION

### CAUTION: COMPRESSED AIR CAN BE DANGEROUS

If this is a new installation, refer to the separate instruction sheet shipped with the PZLD for installing the PZLD. However, it is recommended the heater be installed into the drain prior to installing the drain. If the heater is to be installed in an existing installation, the PZLD reservoir must be depressurized and drained before the heater can be installed.

The heater is designed to thread into the lower optional inlet port on the same side that the control air is connected to. A 3/4" x 1/2" reducer bushing is supplied with the heater. If a plug has been installed, it must be removed (previously installed drain). The use of a non-galling pipe sealant is recommended. Tighten the heater by using the hex nut on the fitting. Do not tighten by using the enclosure. The enclosure will have to be adjusted so that it is horizontal to the ground (see diagram).

Since the heater is an immersion type, it is designed to be immersed in liquid at all times. Therefore, we recommend that the drain be primed with at least 24 ounces of liquid before it is connected to the air system (24 ounces is the usual amount that remains in the reservoir when the drain has completed a drain cycle).

The heater is only designed to prevent the PZLD reservoir from freezing. The inlet and outlet piping must be heat traced separately.

The wiring of the heater is not difficult; however, the use of a qualified electrician is recommended. Proper fittings are required to insure the weather-tight integrity of the enclosure is maintained. Also, it is important that the heater be wired to a circuit that will not be turned off during freezing conditions.

## WARRANTY

The PZLD heater is warranted to be free from defects in workmanship and materials for a period of one year from the date of shipment. The liability of the manufacturer is limited to repair or replacement of the drain at its option. In no event shall the manufacturer be liable for special or consequential damages or for delay in performances of this warranty.

**CAUTION:** Any attempt to repair the drain without authorization will void any warrant

## INSTALLATION DIAGRAMS

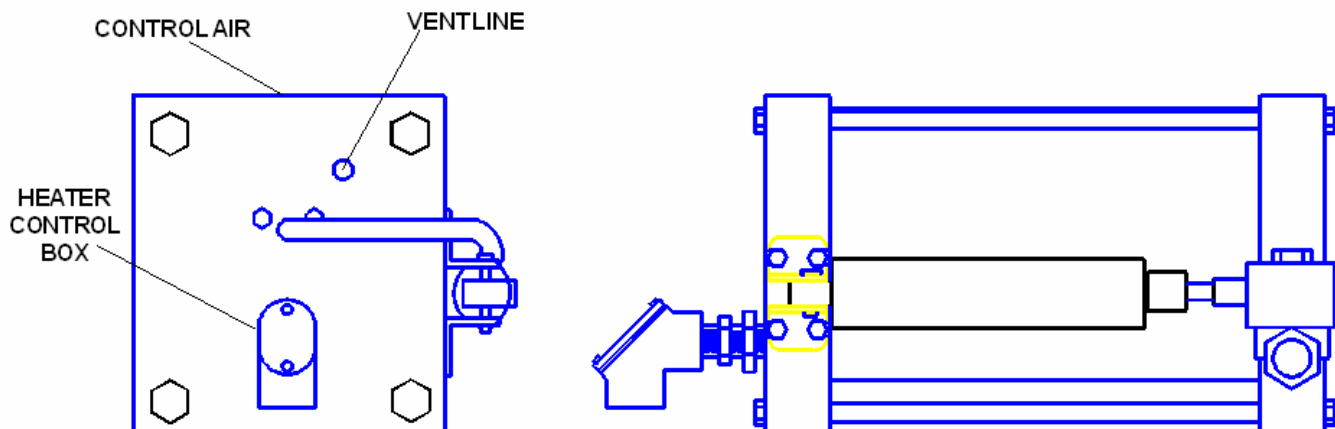

**PSB Industries Inc.**  
General Air Division  
1202 West 12<sup>th</sup> Street • Erie, PA 16501 USA  
Phone: 814-453-3651 • Fax: 814-454-3492  
[www.PSBINDUSTRIES.com](http://www.PSBINDUSTRIES.com)